

**Montgomery  
Ward**

**Montgomery  
Ward**

Household  
help!

## Robot Vacuum



## Instruction Manual

Montgomery Ward Customer Service  
8:00 am to Midnight, Monday through Friday

Item: 779509

**Wards.com 1-888-557-3848**

**Wards.com 1-888-557-3848**

# Montgomery Ward

Thank you for your purchase!

Thank you for purchasing your Montgomery Ward Robot Vacuum. Put through the paces by the experts, we guarantee that it will perform to the highest standard, time after time, with all the convenience, easy cleanup and durability you rely on from Wards.

## Table of Contents

Important Safeguards .....	3
Electrical Safety .....	4
Specifications .....	4
Parts & Features.....	4-5
How to Use .....	6-9
Cleaning & Care.....	10
Troubleshooting .....	11
Return Information .....	12
Warranty.....	13

### READ CAREFULLY BEFORE USING AND SAVE THESE INSTRUCTIONS!

- FOR HOUSEHOLD USE ONLY. DO NOT use this appliance for other than its intended use.
- Remove all packaging materials and labels before first use.
- DO NOT drape the charger cord where it can be pulled on or tripped over.
- We DO NOT recommend using an extension cord with this appliance. However, If an extension cord is used, the marked electrical rating should be at least as great as the electrical rating of this appliance.
- CLOSE SUPERVISION IS NECESSARY WHEN USING THIS APPLIANCE NEAR CHILDREN AND PETS.
- A FIRE MAY OCCUR IF THIS APPLIANCE IS USED NEAR FLAMMABLE MATERIALS, LIGHTERS OR MATCHES.
- DO NOT place the appliance or its cord on or near a heated surface or in a heated oven.
- DO NOT use the vacuum to pick up spills of bleach, paint or any chemicals.
- DO NOT use near water or damp areas (bathrooms or laundry rooms).
- DO NOT use this product in high-temperature environments, under direct sunlight or near mirrors for an extended time.
- Inform all people in the house when the product is operating.
- DO NOT operate this vacuum on floors that have exposed electrical outlets.
- DO NOT use this vacuum on unfinished, unsealed, waxed or rough floors.
- ALWAYS test this vacuum on a small area before using it to clean a whole room.
- DO NOT use an accessory or attachment not recommended by Wards, as this may cause injury or damage the appliance.
- KEEP HANDS, HAIR AND CLOTHING AWAY FROM ALL MOVING PARTS.
- DO NOT use outdoors.
- Unplug the charger from the outlet before cleaning, removing the battery, transporting or storing the vacuum.
- Turn off and unplug this vacuum when not in use for an extended period.
- THERE ARE NO SERVICEABLE PARTS INSIDE THIS APPLIANCE.
- DO NOT USE AN APPLIANCE WITH A DAMAGED CORD OR PLUG, OR AFTER THE APPLIANCE MALFUNCTIONS OR HAS BEEN DAMAGED IN ANY MANNER.
- Appliances contain valuable materials that can be recycled. Dispose of old appliances and batteries using appropriate collection systems in accordance with federal and local regulations.



## Electrical Safety

The charging base for this appliance is equipped with a detachable polarized plug in which 1 prong is wider than the other. This is a safety feature to reduce the risk of electrical shock. The plug should be attached to the charging base before connecting to an electrical outlet. The plug will fit into a polarized outlet only one way. If you are unable to insert the plug into the outlet, try reversing the plug. If it still does not fit, contact a qualified electrician. DO NOT attempt to modify the plug in any way. Montgomery Ward cannot accept any liability for damage or injury resulting from failure to observe these safety procedures.

## Specifications

<b>CHARGER POWER OUTPUT</b>	<b>14.4V, 28W, 0.6Amp</b>
<b>BATTERY (4 cells)</b>	<b>2500 mAh Li-ion</b>
<b>CHARGE/RUN TIME</b>	<b>3-4 hours/100 minutes</b>
<b>DIMENSIONS</b>	<b>13" W x 3" H x 13" D</b>
<b>DUST BIN CAPACITY</b>	<b>20 oz.</b>
<b>WATER BIN CAPACITY</b>	<b>12 oz.</b>
<b>MODEL</b>	<b>SVC-301</b>

## Parts & Features

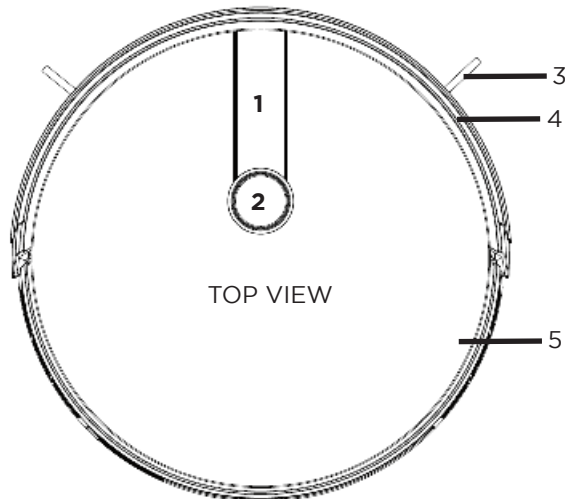

## Parts & Features (cont.)

1. Vacuum Display (Power, Wi-Fi and Home Lights)
2. Power/Auto Clean Button
3. Side Brushes (2)
4. Omnidirectional Lens/Bumper
5. Surface Cover
6. Ground Sensors (3)
7. Swivel Wheel
8. Charging Poles (2)
9. Battery Compartment
10. Flexible Arms (2)
11. Drive Wheels (2)
12. Brush Removal Tabs (2)
13. Dust Box Release Button
14. Removable Dust Box
15. Rolling Brush Assembly
16. Charging Dock with Cord (not shown)
17. Removable Water Tank (not shown)
18. Washable Mopping Pads (2, not shown)
19. Remote Display
20. Remote Auto Clean Button
21. Remote Start/Stop Button
22. Remote Schedule Button
23. Remote Mode Button
24. Remote Directional Buttons (4)
25. Remote Clock Button
26. Remote Home Button

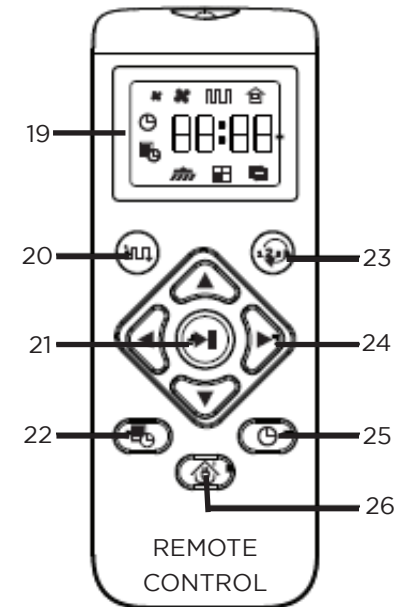
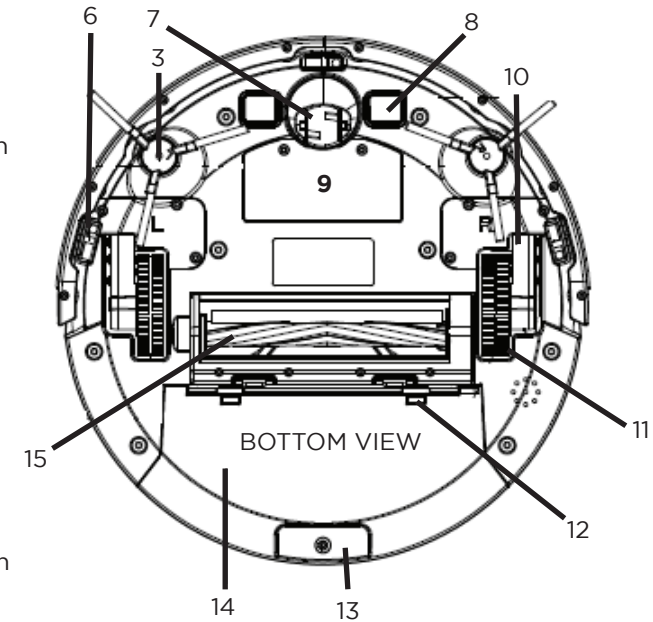

Remote control uses 2 AAA batteries (included)

**WARNINGS:**

- **Before first use, remove and discard the 2 foam strips from the sides of the vacuum and install the 2 side brushes on the bottom (see locations on page 5, #3).**
- **DO NOT use this vacuum on long plush carpets or rugs (over ¼") or on dark-color floors.**
- **Curtains, fringes, cords, papers, clothing or other objects may get caught up in the wheels or brushes. Pick up these objects before operating the vacuum.**
- **DO NOT place anything on top of this vacuum or attach any object to it.**
- **Only use the original battery and charging dock. Other unmatched batteries and chargers may cause electric shock, fire or product damage.**
- **Fully charge the vacuum before first use (may take up to 5 hours).**

**Charge**

1. Connect the power cord to the charging dock.
2. Place the charging dock against a wall and remove obstacles from 1 yard on each side and 2 yards from the front.
3. Plug the cord into an outlet. The green light on the dock will flash.
4. Place the vacuum onto the charging dock, aligning the charging poles. **Charge only with the dust box attached, never with the water tank.**
5. Press POWER on the vacuum. POWER will light up on the vacuum and HOME will flash on the vacuum. The HOME light will be solid green when fully charged.

**Operate**

1. For cleaning the whole house, press POWER on the vacuum or press AUTO CLEAN on the remote once for a bow-shaped path. Press AUTO CLEAN again to activate super suction.
2. Press MODE on the remote once to set the path to spot cleaning.
3. Press MODE on the remote again to change the path to single-room cleaning and close all doors to the room. (This mode uses super suction automatically.) When done, the vacuum will not be able to return to the charging dock unless the dock is installed in this room.
4. Press MODE on the remote 3 times to select perimeter cleaning (the vacuum will move around the edge of the room).
5. Manually change the path of the vacuum by pressing the directional buttons on the remote control (forward, backward, right or left).
6. Press START/STOP on the remote or POWER on the vacuum to stop and start the vacuum.
7. When done, the vacuum will automatically go back to the charging dock for recharging (or press HOME on the remote).

**Note:** If stationary for more than 10 minutes (off the charging dock), the vacuum will switch to *sleep* automatically. Press START/STOP on the remote or POWER on the vacuum to restart.

**Recharge**

1. When the battery is low, press HOME on the remote control and the vacuum will return to the charging dock (or you can pick up and place the vacuum onto the dock).
2. When the vacuum is operating and the battery gets low, the vacuum will automatically go back to the charging dock for recharging.
3. When not in use, turn off the vacuum to preserve the battery charge.

**Set the Clock**

1. Make sure the vacuum is on, then press CLOCK on the remote control.
2. The display will flash. Press FORWARD/BACKWARD arrows to set the hour.
3. Press LEFT/RIGHT arrows to change from hour to minutes.
4. Press FORWARD/BACKWARD arrows to set the minutes.
5. Press CLOCK to save the setting.
6. If the remote control batteries are changed, the clock will need resetting.

**Schedule a Cleaning Plan**

1. Make sure the vacuum is on, then press SCHEDULE on the remote control.
2. The display will flash. Press FORWARD/BACKWARD arrows to set the hour.
3. Press LEFT/RIGHT arrows to change from hour to minutes.
4. Press FORWARD/BACKWARD arrows to set the minutes.
5. Press SCHEDULE to save the setting.
6. To cancel the cleaning plan, reset to 00:00 and press SCHEDULE to save.

## Dust Bin

1. Turn the power switch to OFF on the vacuum and remove from the charging dock.
2. Remove the dust bin by pressing RELEASE on the back of the vacuum.
3. Open the door to empty contents into the trash. Close the door.
4. Open the filter door to clean or change the filters (see page 10, #8)
5. Replace filters and close the filter door.
6. Securely reattach the dust bin to the vacuum.

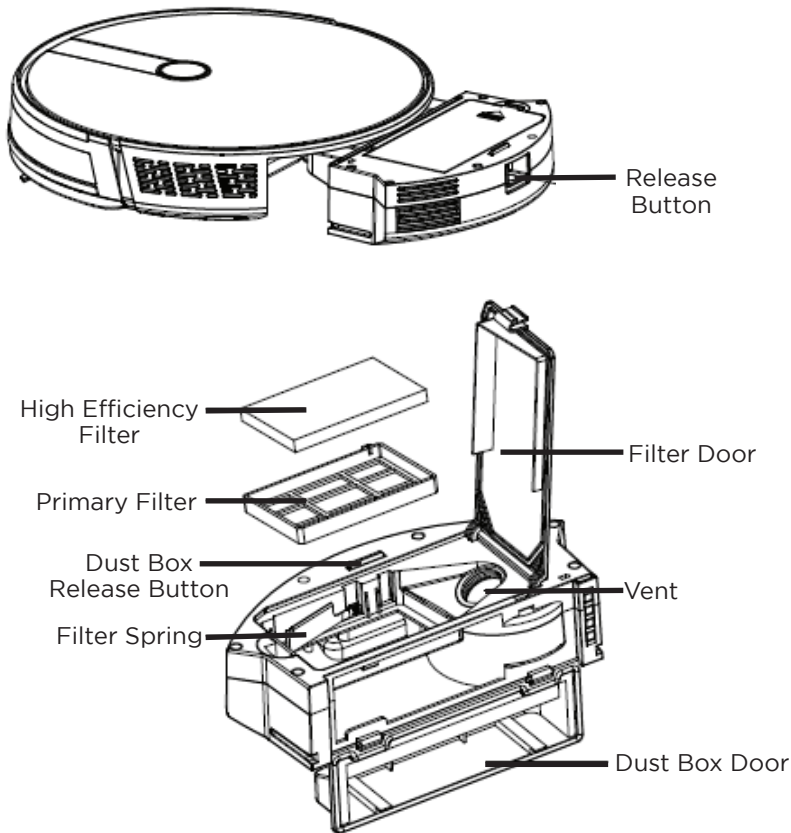

## Water Tank

**WARNING: Use clean water only! DO NOT add detergent or other cleaners to the water tank.**

1. The water tank for mopping is interchangeable with the dust box. DO NOT install the water tank when the robot vacuum is charging.
2. Turn the power switch to OFF on the vacuum and remove from the charging dock.

**WARNING: Be sure your hard surface floor is safe for mopping (check with flooring manufacturer, if needed). DO NOT use the water tank on carpets or rugs.**

3. Using the hook and loop tabs, attach a pad to the bottom of the water tank.
4. Open the rubber plug and add water to the water tank. Close the plug.
5. Securely attach the water tank to the vacuum and operate the vacuum as explained on page 5. Remove the tank and add more water, as needed.

**Note:** The water tank is for *damp mopping* only. This vacuum is not intended for cleaning up large wet spills.

6. When finished mopping, remove the tank from the vacuum and empty any remaining water and dirt from the tank. Allow the water tank to air dry before reattaching to the vacuum or storing away.
7. The mop cloth is machine washable.
8. Reinstall the dust bin before returning the vacuum to the charging dock.

## Use the Smart Life Application

1. Install the Smart Life/Tuya application on your cell phone or tablet.
2. Open the application and follow the instructions to register an account and login.
3. Click "add device." Click "+" and "all." Select "robot vacuum."
4. Press POWER on the vacuum twice and when the light is flashing, select "confirm indicator rapidly blinking" on the application.
5. Follow the instructions from the application to connect to your Wi-Fi (compatible with 2.4GHz only) and operate the vacuum.

## Cleaning & Care

1. Turn off the vacuum and remove it from the dock.
2. DO NOT use abrasive brushes, pads or cleaning solutions.
3. Gently pull off the side brushes and clean with water, if needed.
4. Remove the rolling brush and gently pull free any items caught on the bristles.  
Use a scissors, if needed, to cut free wound up hair, strings or other debris.
5. Wipe the wheels with a damp cloth and dry thoroughly.
6. Clean the charging poles, sensors and charging dock with a soft cloth.
7. Empty the dust box after every use and wipe it with a soft cloth. See page 8.
8. Remove the filters every week and clean gently with a soft brush. The primary filter can also be cleaned with water, but be sure to dry thoroughly before reinstalling.
9. Wipe the exterior of the vacuum with a damp cloth and dry thoroughly.
10. **DO NOT immerse the vacuum, charging dock, cord or plug into water.**

## Troubleshooting

Error	Cause	Solution
The vacuum does not back off the charging dock.	Vacuum is OFF.	Press POWER. The POWER light is green when on.
	The vacuum battery is not charged.	Make sure the vacuum is sitting correctly on the charging base so the battery charges.
The vacuum movement is erratic or the vacuum keeps turning in circles.	Debris is caught in the roller brush or wheels.	Clean the roller brush and wheels.
	Sensors are dusty.	Clean the sensors.
	Bumper is stuck on an object.	Redirect the vacuum using the arrow buttons on the remote control.

If any item, for any reason, does not meet your expectations, just return it to us. We'll gladly either:

- Refund your merchandise amount
- Credit your account
- Send a replacement

You can return any unused item in its original packaging within 60 days of its receipt for a full refund of the purchase price (excluding shipping and handling charges).

**Please send returns to:**

**Montgomery Ward, Inc.  
Attn: Customer Returns  
2000 Harrison Suite 100  
Clinton, IA 52732-6676**

**When returning an item:**

- Use the original packaging and pack it securely.
- Please adequately insure your item in case you need to make a claim with the carrier you choose for returning your item.
- Include your order number and reason for return.
- We recommend keeping the receipt for 4 weeks.

# Montgomery Ward<sup>®</sup>

## 1 Year Limited Warranty

Montgomery Ward, Inc. warrants this product to be free from defects in material and workmanship for one year from provable date of purchase.

Within this warranty period, Montgomery Ward will repair or replace, at its option, defective parts of this product at no charge provided the product is returned freight prepaid with proof of purchase to Montgomery Ward.

Allow 2-4 weeks for return shipping.

This warranty does not cover improper installation, misuse, abuse or neglect on part of the owner. Warranty is also invalid in any case that the product is taken apart or serviced by an unauthorized service station.

This warranty gives you specific legal rights and they may vary from state to state.

THE FOREGOING WARRANTIES ARE IN LIEU OF ALL OTHER WARRANTIES AND CONDITIONS, EXPRESS OR IMPLIED, INCLUDING BUT NOT LIMITED TO THOSE OF MERCHANTABILITY OR FITNESS FOR A PARTICULAR PURPOSE.

Montgomery Ward Customer Service  
8:00 am to Midnight CST, Monday through Friday

**Wards.com 1-888-557-3848**

